



System solutions for industry

HP -Pneumatics

Water- and Special- Fluid Hydraulic

Equipment for Road Safety Training Centres

Accessories for Tundish Systems

Fire Fighting Systems for Transformers

Live Line Washing Systems for Insulators

HL Hydraulik GmbH

Kupferhütte 5c
D-57562 Herdorf
Tel: +49(0)2744/9324-0
Fax: +49(0)2744/9324-56
schrupp@hl-hydraulik.de

www.hl-hydraulik.de

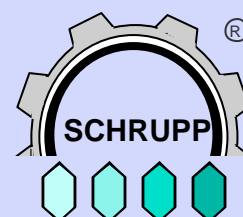

JAN09

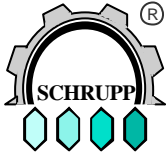

HP – PNEUMATIC

System Solutions for Industry



HP Pneumatic Valves
HP Pneumatic Dryers
HP Pneumatic Compressors
HP Pneumatic Systems



PRODUCT RANGE

www.hl-hydraulik.de



Hand Operated Valves

PN 64 - DN 15, 25
PN 350 - DN 8

Type
HAV 15, HAV 25
HAV 08

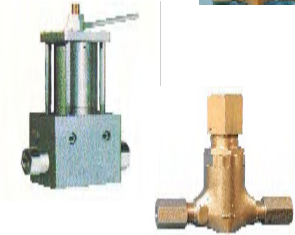

Pressure Maintaining Valves

Non Return Valves
PN 60 - DN 16
PN 350 - DN 5

Type
DHV 16/12
DHV 05, DRV 05

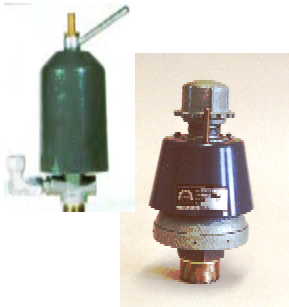

Safety Valves

PN 350 - DN 6
PN 40 - DN 30/15

Type
SVE 06
SVE 30/15

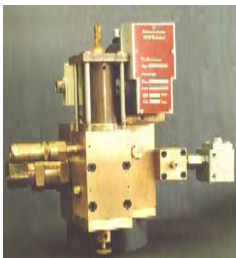

Safety Devices

PN 64 – DN 20
PN 200 – DN 10

Type
SHE 06
SHE 20



Pressure Reducing Valves

PN 200 – DN 8

Type
DMV 08

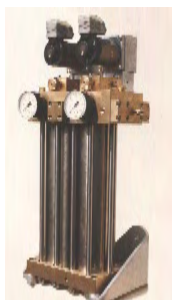

Gas Driers

PN 250 /350bar
Q 1300-3900L/min

Type
GTR/GTF 10

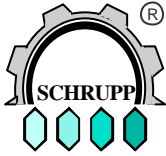

WATER AND SPECIAL HYDRAULICS

System solutions for Industry

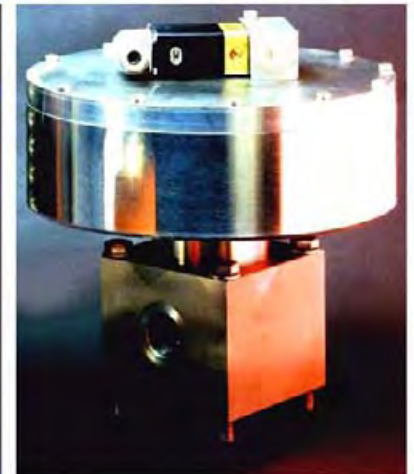
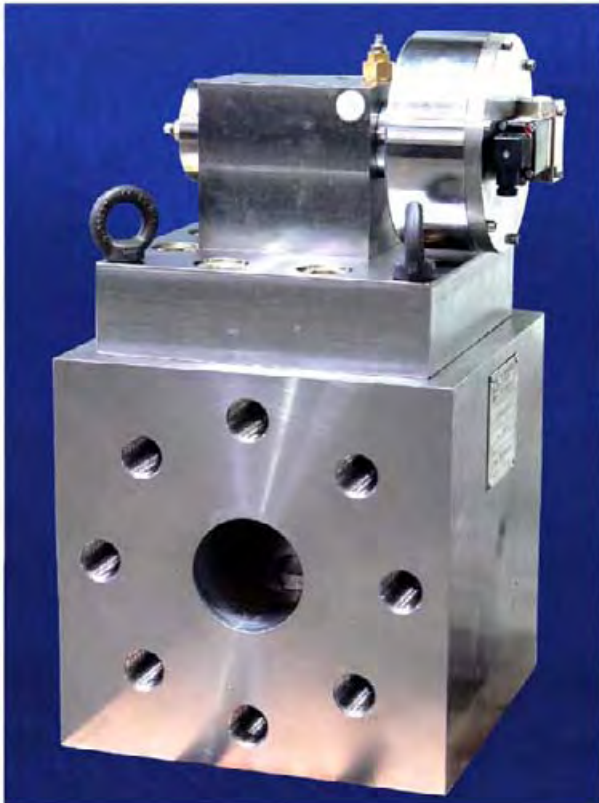
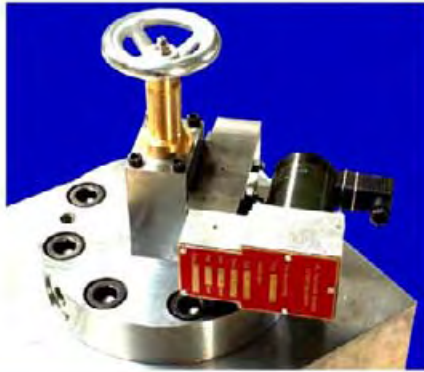

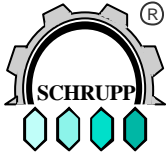

WATER AND SPECIAL HYDRAULICS

System solutions for Industry



CARTRIDGE VALVES

Directional-, pressure, and flow regulation valves for water, air and special fluids.

Sizes: 10 to 100mm

Pressure range: standard 350bar and up to 800bar

Cartridge dimensions to DIN standard



DESCALING VALVES

Size 10 to 250mm cartridge-type NP 350bar, pilot valves, manifolds, orifice assemblies and accessories.



SPRAYING VALVES

For aluminium and steel rolling mills

Size 6 to 25mm.

Valves, pilot valves, spray bars and accessories.



MANIFOLDS AND HOUSINGS

According to DIN or ASME upon customers request



Stainless Steel Cartridge valves according to DIN24342

The valves are designed for use with water, water and oil emulsions, oil and gases. Their robust construction and compact design provide long life, ease of maintenance, and high performance.

These slip in cartridge type valves can be combined in many different ways to satisfy the requirements of a wide variety of applications. The sealed poppet design provides drop tight, leak free shut off.

Product range:

Cartridges for directional functions

Soft seated ND10 to 100 for water, oil and pneumatic applications up to 350bar

Soft seated ND10 to 250 for water, descaling water and oil up to 350bar

Soft seated ND10 to 40 for water, oil and pneumatic applications up to 800bar

Hard seated ND 16 to 32 water and oil up to 350bar

Cartridges for pressure relief functions

Hard seated ND 16 to 32 for water and oil up to 350bar

Cartridges for pressure reducing functions

Hard seated ND 16 to 32 for water and oil up to 350bar

CARTRIDGE PROGRAM

www.hl-hydraulik.de

Functional description

These valves are designed for use with special fluids:

- No metal to metal contact at the sliding surfaces.
 - the use of non-lubricating mediums is possible.
- All pressurized areas are separated by soft seals
 - for thin fluids and gases under high pressure.
- Special geometry and non-corroding material
 - for water and descaling applications.

An important dimension for the function of cartridge valves is the surface ratio of the seat area A_a and the annulus area A_b to the pilot area P_x . By using a surface ratio of 1:1 the valve can be operated only in one direction. By using a surface ratio of 1:1.6 or 1:2 the valve can be operated in both directions, but cannot be used for pressure functions because of the pressure ratio which creates pre-opening of the pilot valve.

Soft-seated valves are suitable for use in shut-off and directional functions. These valves are absolutely leak-free even for long-term operation in gas or high-pressure circuits. Hard seated valves are suitable for use in pressure control functions. Because of their robust seats they can be used also in high pressure water hydraulic circuits.

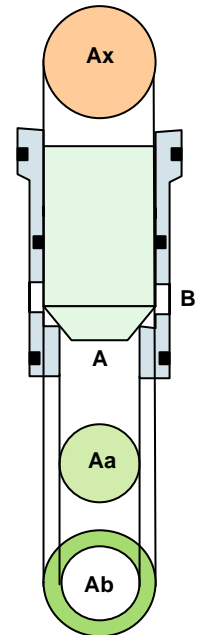

Diagrams

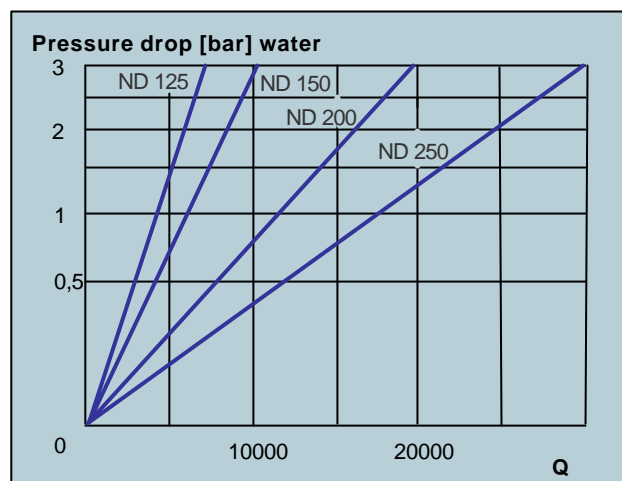
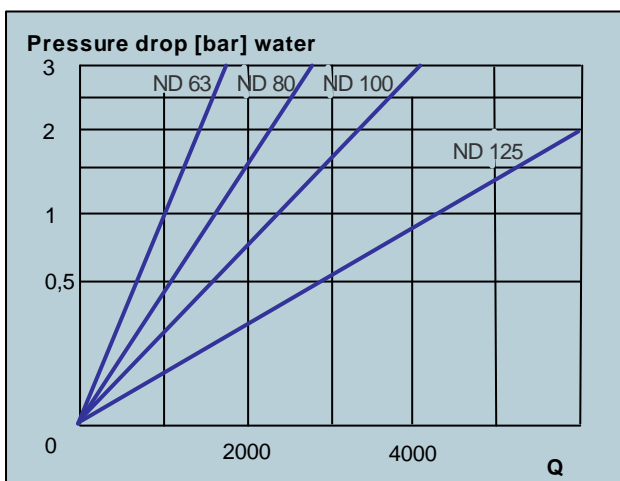
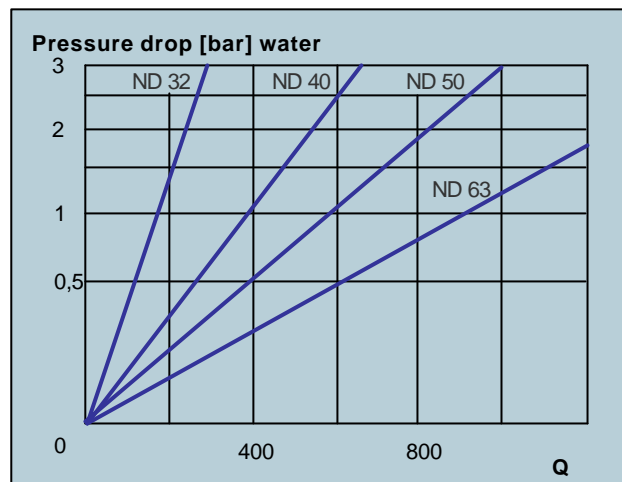
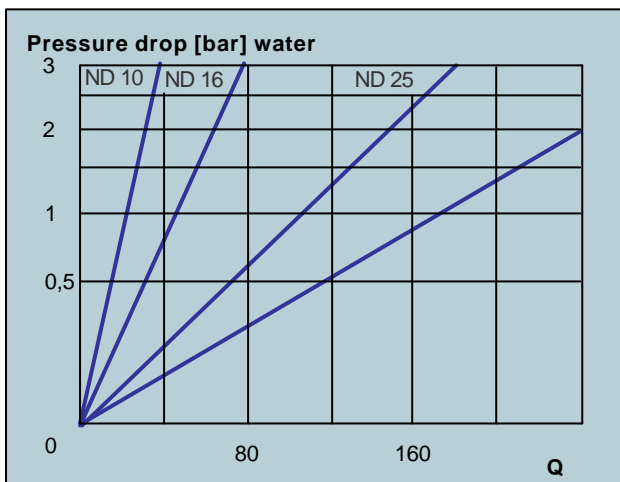



Entzunderungssysteme werden in Stahlwerken eingesetzt, um nach jedem Walzvorgang die Zunderschicht von der Materialoberfläche zu entfernen. Ohne ein effektives Entzunderungssystem können die heutigen Qualitätsanforderungen an Stahlprodukte nicht mehr erfüllt werden. HL Hydraulik GmbH fertigt und vertreibt unter dem Handelsnamen Schrupp die hierzu erforderlichen Ventile sowie mehrstufige Bypass Düsen.

Das Produktprogramm umfasst

- Absperrventile
- Rückschlagventile
- Magnetbetätigte Ventile
- Ventilkombinationen
- Düsenpakete
- 2- und 3- Wege Vorsteuerungen

Die Ventile sind einsetzbar bis zu Drücken von 350bar (Sonderanwendungen bis 800bar) und Volumenströmen bis 30.000 l/min

Descaling systems are used in steel rolling mills to remove the scale after each rolling procedure. Without a modern descaling system it is not possible to produce a high quality steel product. HL Hydraulik GmbH is manufacturing all kinds of valves and multistage break down orifices under the trade name Schrupp for this kind of applications.

The product range includes:

- On Off valves
- Non Return Valves
- Automatic Valves
- Valve Combinations
- Multistage Break Down Orifices
- 2 and 3 Way Pilot Valves

The valves are suitable for pressures up to 350bar (special applications up to 800bar) and flow rates up to 30.000 l/min

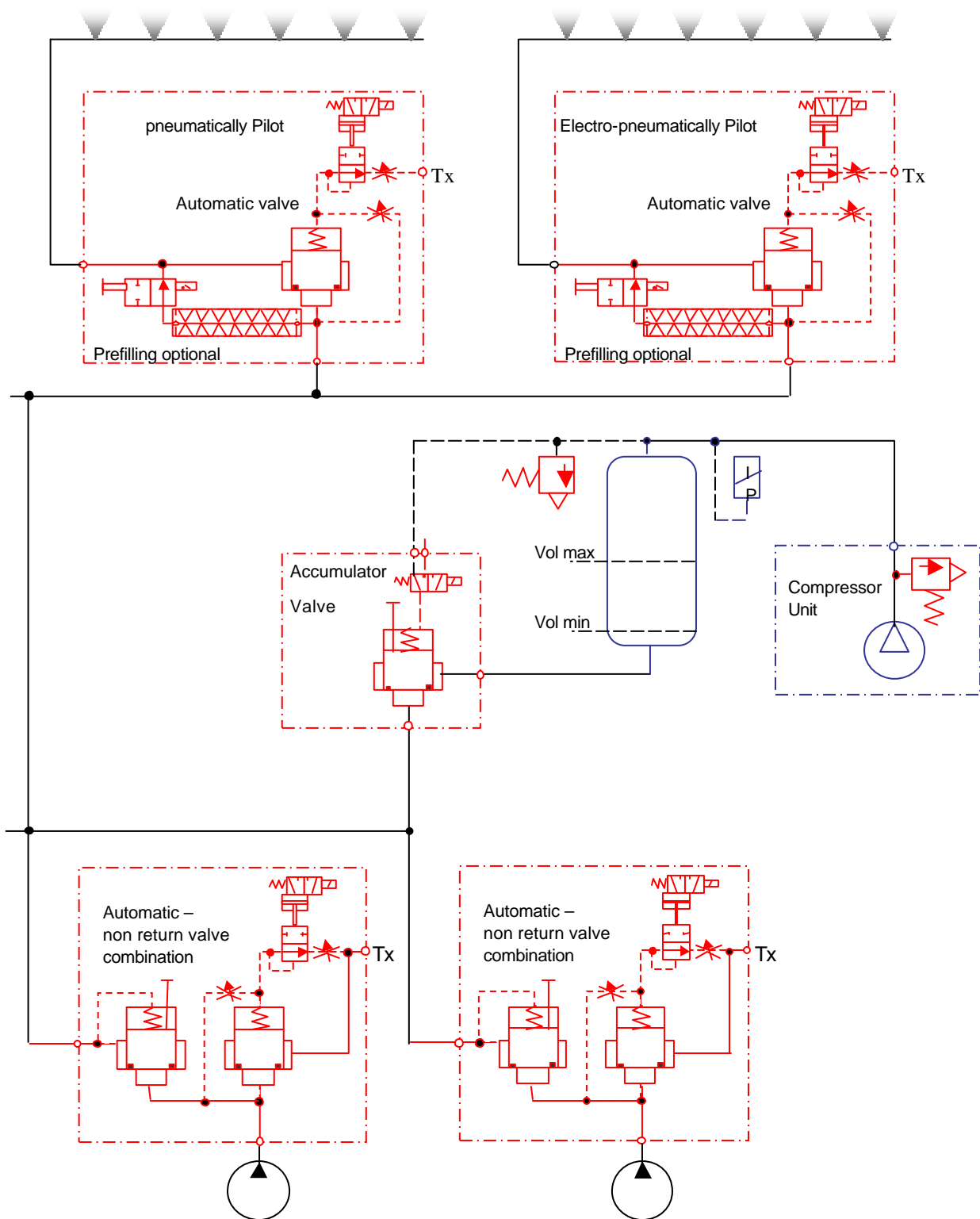

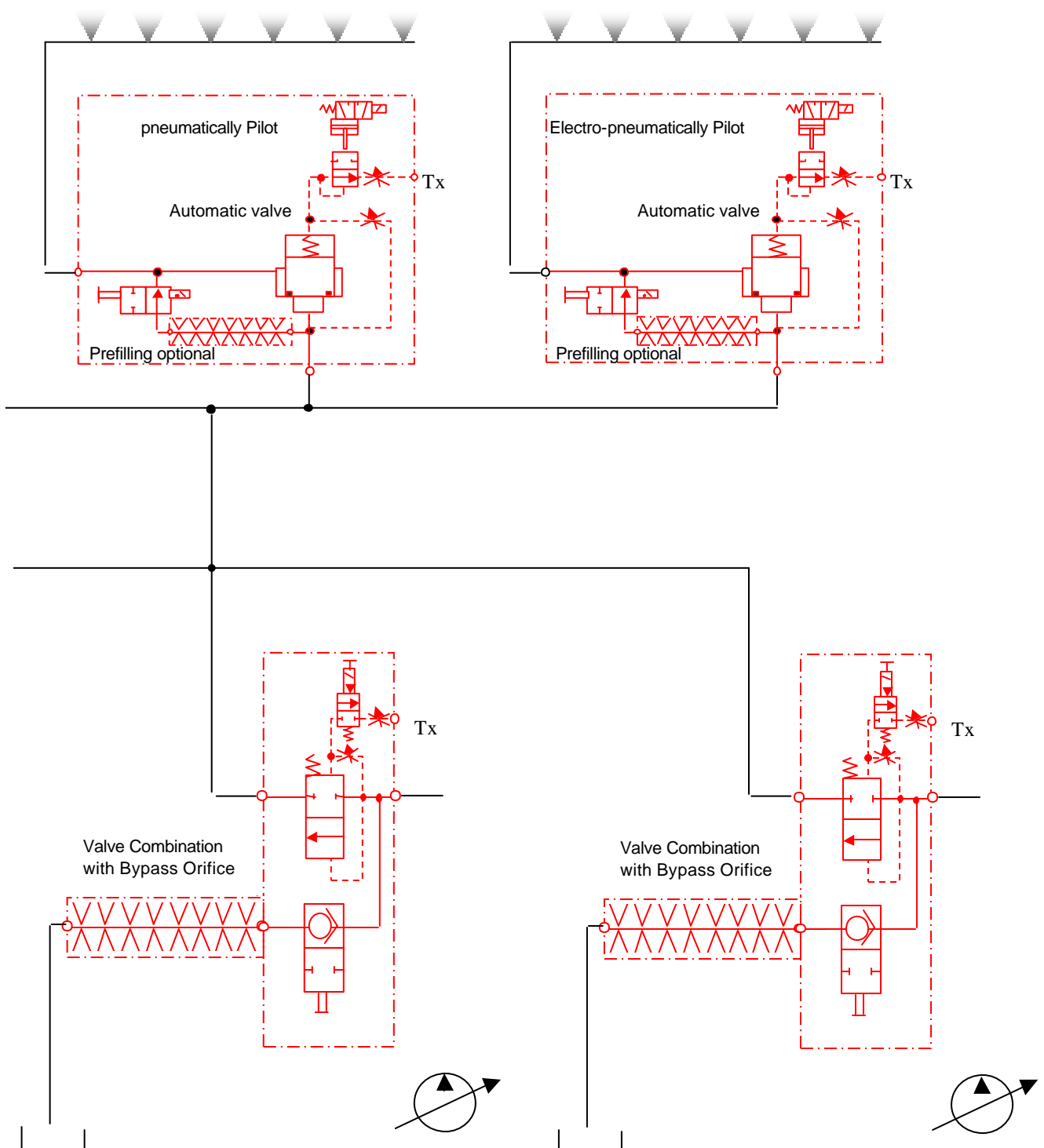



**SPRÜHVENTILE
SPRAY VALVES**

HL Hydraulik GmbH

Kupferhütte 5c
D-57562 Herdorf
Tel 02744-9324-0
Fax 02744-9324-56
schrupp@hl-hydraulik.de

www.hl-hydraulik.de



**Leckagefreies Sitzventil
Beständig gegen übliche Medien zur
Walzenkühlung
Sprühdüse kann integriert werden
Zum direkten An- oder Einbau in Sprühbalken
Geringe Abmessungen
Kurze Schaltzeiten
Lange Lebensdauer**

**Non-leak valve with soft seat
Resistant to cooling medias
Spray nozzle can be integrated
Assembly in or onto spray
beams
Small size
Short actuating time
Long expected lifetime**



ANWENDUNG / APPLICATION

Moderne Walzverfahren zur Herstellung von Feinblech aus Aluminium oder Stahl erfordern eine schnell ansprechende partielle Walzenkühlung eng aneinander liegender Walzenzohren.

Schrupp Sprühventile lassen sich direkt in oder auf den Sprühbalken montieren. Die Sprühdüse kann in das Ventil integriert werden. Ein einfacher und robuster Aufbau ermöglicht den Aufbau einer kompakten und schnell reagierenden Walzenkühlung.

Modern rolling processes for the production of aluminium or steel sheets require a quick acting valve to provide partial cooling of roller areas situated close to each other. Schrupp spray valves can be assembled in or onto the spray beam. The spray nozzle can be integrated into the valve. With their ease of maintenance and robust design the valves can be used in rapidly responding compact roller cooling systems.

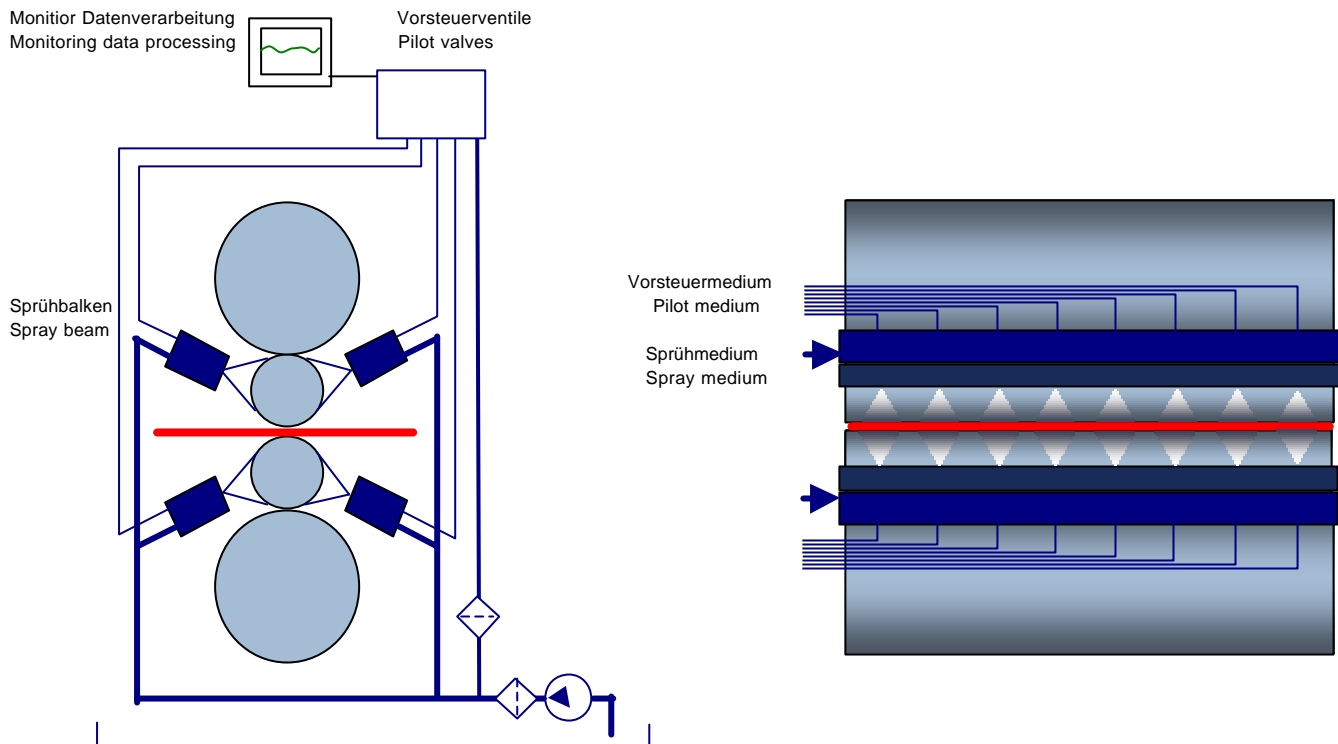

Zu unserem Lieferprogramm gehören:

Sprühventile
Sprühbalken
Vorsteuerventile und Stände
Verbindungstechnik

Our manufacturing program includes:

Spray Valves
Spray Beams
Pilot Valves and Valve Stands
Piping and connections



SLIDING GATE VALVES FOR LADLES

Single nozzle valves and spareparts

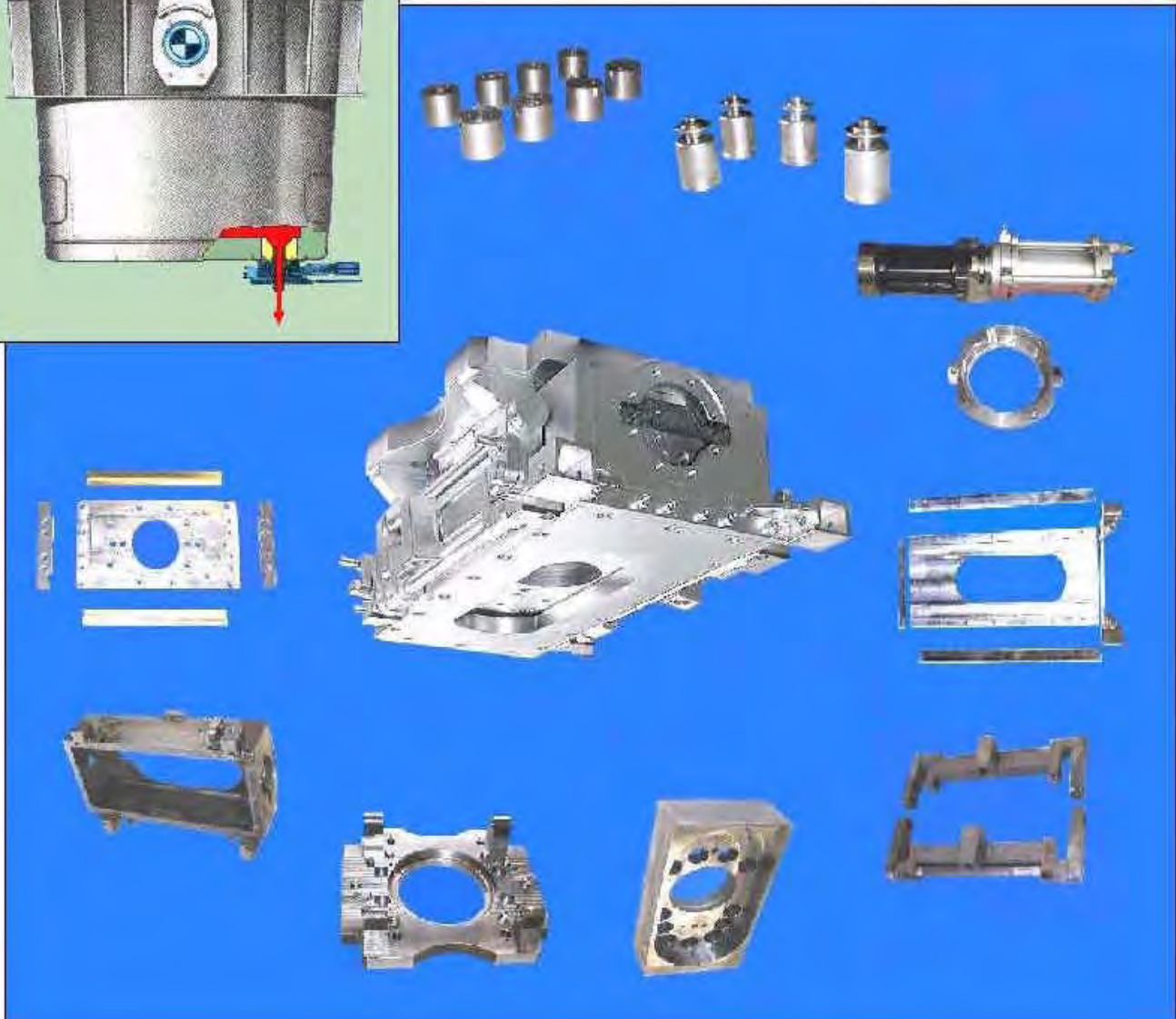
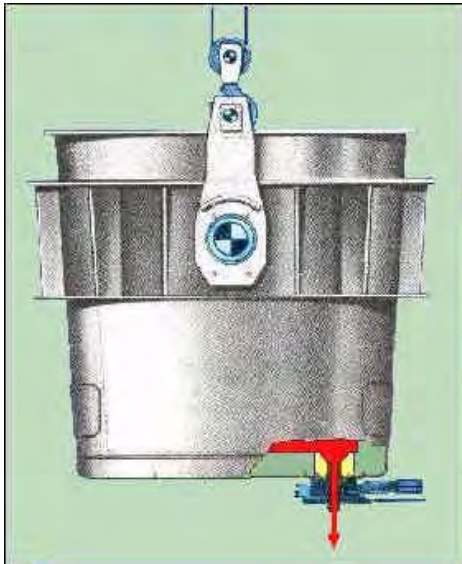

HP -Pneumatics

Water- and Special- Fluid Hydraulic

Equipment for Road Safety Training Centres

Accessories for Tundish Systems

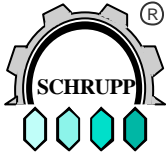

Sliding Gate System - FloCon Typ 42xx / 63xx

HL Hydraulik GmbH is the only supplier of FLOCON products under the trade name SCHRUPP. Until 1990 SCHRUPP was an subsidiary company of Zimmermann & Jansen, Germany and was the first producer of FLOCON SLIDING GATE VALVES and SPAREPARTS. Continuous development and an experience of more than 20 years allows improvements to this program to follow the requirements of the market.

So we can offer "Original - FloCon" products with a high quality standard to a favorable price. This Catalog is only a overview of our productlist and spareparts.

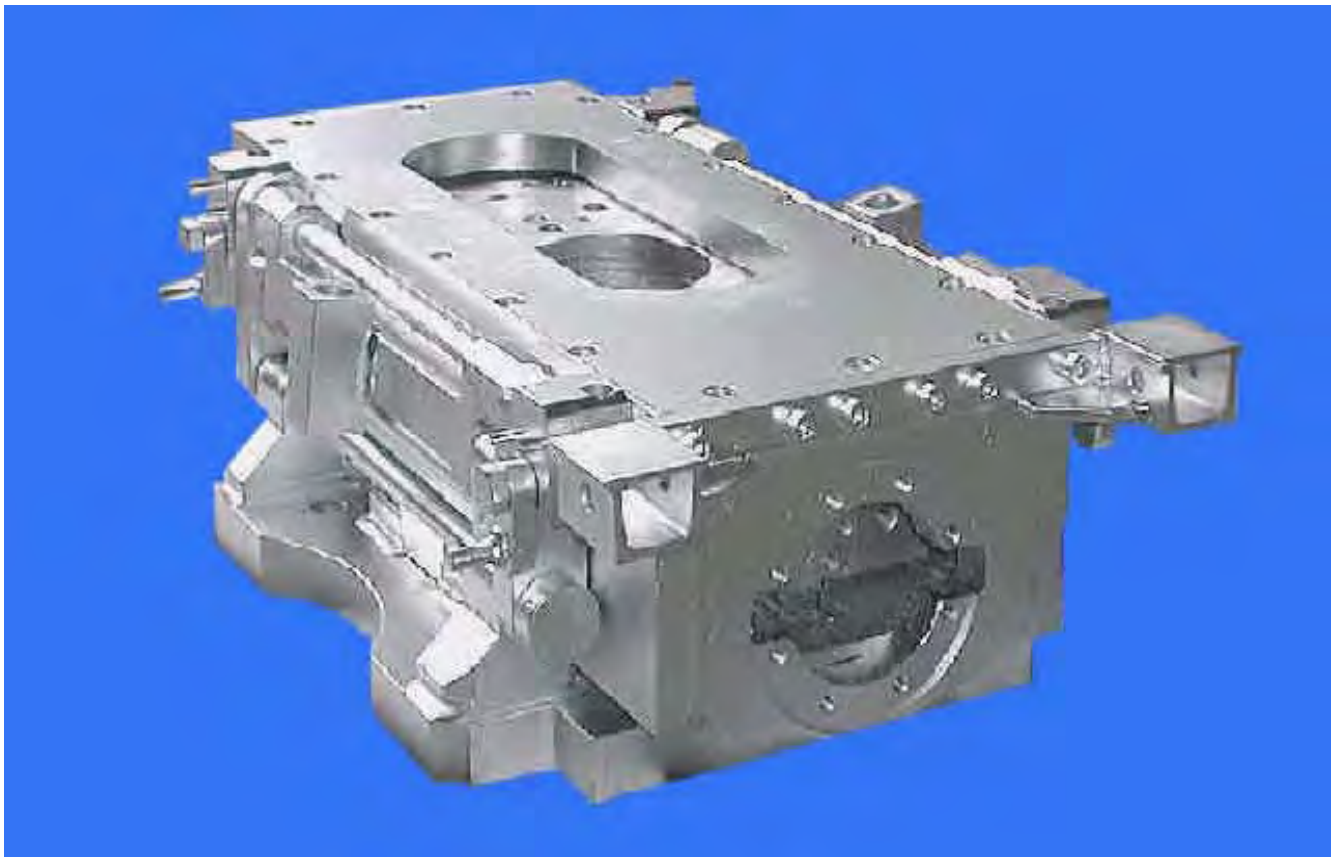

Tundish System Typ 4200 / 6300

Typical Spareparts



Clamping cylinder and connection

The movement of the sliding frame will be controlled by the cylinder wich is coupled to the sliding frame.

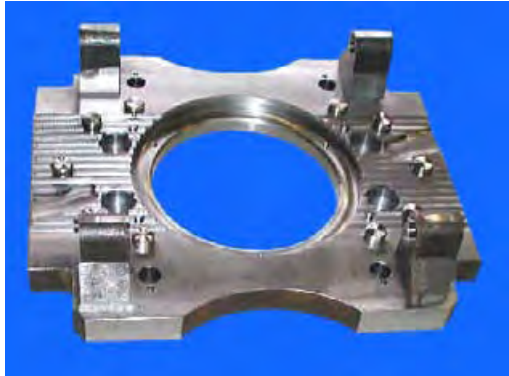

Mounting Plate

The basic assembling sheet is screwed on the main frame which is welded to thundish bottom.



Permanent Magnets (Holding System)

The mounting plate are equipped with permanent magnets to keep the head disk in position. The magnets are fixed by headless bolts. During maintenance the retention force of the of the magnets has to be checked.



Thundish valve housing

The thundish valve housing guides the sliding frame.

Floor plate for thundish valve housing with Fixing Elements and Sliding Strips

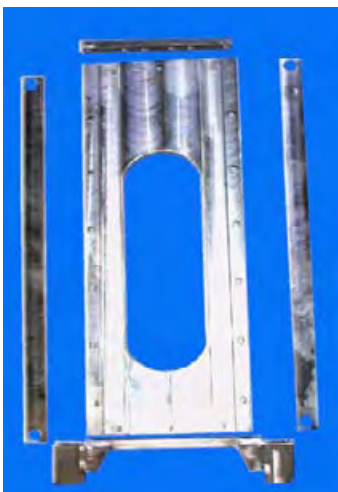

Sliding Frame



Insert Ring

During operation the centering plate can be damaged. If this happens the insert ring has to be replaced.

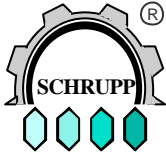

Swivel Frame of closing system

Each valve includes a closing device on both sides. This elements are under permanent mechanical stress during operation and must be checked regularly and replaced if necessary.

Floor plate - gliding frame with Fixing Elements and Sliding Strips

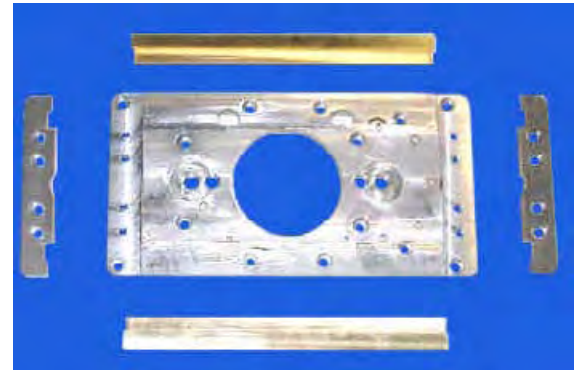

Thermodynamic-spring elements

TD - Elements

The basic assembling sheet are equipped with permanent magnets to keep the head disk in position. The magnets are fixed by headless bolts. During maintenance the retention force of the magnets has to be checked.



Test unit for thermodynamic-spring elements

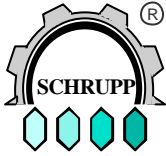

Isolatoren Reinigungssysteme

Live Line Insulator Cleaning Systems

Feuerlöschsysteme für Transformatoren

Fire Fighting Systems for Transformers



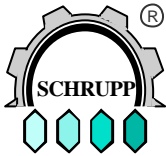

Isolatoren-Reinigungsanlagen / Insulator hot line washing systems

Wir liefern komplette Systeme für die Energieversorgung, z.B. für Umspannwerke und Kraftwerke. Während des Reinigungsvorgangs kann der elektrische Strom fließen. Unsere Anlagen können automatisch oder manuell betrieben werden, wobei Wasserleitfähigkeit, Verschmutzung sowie Windgeschwindigkeit und Richtung regelungstechnisch berücksichtigt werden.

We are manufacturing live line washing systems for power stations and substations to secure energy supply. Our live line washing plants can be operated automatically or manually. Essential parameters like water conductivity, dirt contermination, windvelocity and direction can be monitored by our automatic control system.

Betriebsdruck	8 bis 15bar
Medium	Wasser, max 150 uS
Pumpe	Je nach Düsenanzahl
Behälterinhalt	Ausreichend für eine Waschdauer von 1-5min
Düsen	Flachstrahldüsen 30°-120° 18-25l/min
Werkstoffe	Rohre und Zubehör - Stahl, feuerverzinkt; Düsen -Messing; Tank 400 um Innenanstrich, 200 um Grundierung außen.

Operating pressure	8 to 15bar
Medium	Water, max 150 uS
Pump capacity	Depending on number of nozzles
Tank capacity	Sufficient for a washing period of 1-5min
Nozzles	Flat discharge nozzle 30°-120°, 18-25l/min
Material	Piping – hot galvanized carbon steel; nozzles – brass; Reservoir 400 um inside coating, 200 um outside primer.

Für die Ausarbeitung eines Angebotes erbitten wir Zeichnungen des Waschojektes mit einem Lageplan der Anlage und Angaben über die Art der Wasserversorgung.

In order to submit a quotation we require drawings of the object to be washed, a site plan and information about the water supply system.

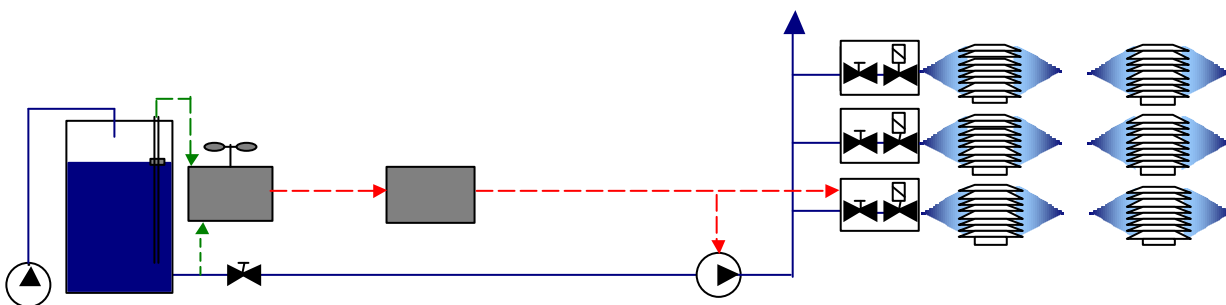

Tankanlage	Meßstationen	Steuerstation	Pumpenstation	Ventilstände	Abspritzgruppen
Reservoir group	Monitoring systems	Automatic control cabinet	Pumping Station	Valvestands	Washing groups



Isolatorenreinigungsanlagen können für nahezu alle Isolatorentypen eingesetzt werden. Speziell angepaßte Rahmen mit individuell einstell- und austauschbaren Düsen ermöglichen eine einfache Montage. Anders als bei mobilen Systemen ist eine allseitige Reinigung des Isolators bei geringstmöglicher Wasserverbrauch unter Spannung möglich. In Abhängigkeit von Länge und Durchmesser der jeweiligen Isolatoren werden daher zwischen 3 und 8 Düsen mit verschiedenen Sprühwinkeln eingesetzt.

Insulator Live Line Cleaning Systems can be used for nearly each insulator type. Special cleaning frames with individual adjustable and interchangeable nozzles allow a comfortable installation. In difference to mobile systems it is possible to clean the insulators from all sides with a minimum of water consumption. Depending on the length and dimension of the Insulator the cleaning frame includes between 3 and 8 nozzles with different spraying angles.



Das demineralisierte Wasser kann in Hoch- oder Erdtanks zentral bevorratet werden. Pumpen, Mess- und Regeleinrichtungen sind in einem Gebäude untergebracht um sie vor Umwelteinflüssen zu schützen. Die elektrisch betätigten Absperrventile befinden sich in separaten Ventilschränken in der Nähe der jeweiligen Waschgruppen.

The demineralized water can be stored in a central reservoir in or above ground. Pumping unit and electrically operated controls are located in a separate building, to protect the equipment against environmental conditions. The electrically operated shut-off valves are located in separate cabinets close to the individual washing group.

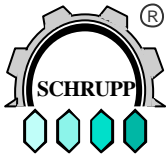

Feuerlöschanlagen / Fire fighting systems

Wir liefern komplette Systeme für den Transformatorenschutz, wobei die Energie zur schnellen Versorgung der Löschkäfige in Druckbehältern gespeichert wird. Dadurch kann das System im Gefahrenfall vollkommen unabhängig von Fremdenergie betrieben werden. Die Auslösung des Systems kann mittels Schmelzdüsen, elektrisch oder manuell erfolgen. Die Löschkäfige sind freitragend und mit Kupplungen versehen, so dass ein eventuell notwendiger Austausch der Transformatoren möglich ist.

We are manufacturing complete systems for transformer protection. The energy for quick supply of the fire fighting apparatus will be stored in pressure tanks so that in case of an emergency no external power input is required to operate the system. The spraying cage is cantilever and assembled with particular couplings ready for a quick change of the transformer if necessary. The start up of the extinguishing process will be effected by either melting nozzles, an electrical signal or manually.

Betriebsdruck	10bar	Operating pressure	10bar
Verdichter	275l/min; 10,5bar; 2,5KW	Compressor	275l/min; 10,5bar; 2,5KW
Füllpumpe	6m³/h; 10,5bar; 4KW	Prefilling pump	6m³/h; 10,5bar; 4KW
Behälterinhalt	Ausreichend für min 5min Löschdauer	Tank capacity	Sufficient for min 5min operation
Heizungsanlage	Umlaufheizung nach Bedarf	Heater	Circular heating system if required
Düsen	Vollkegeldüsen ca. 50l/min; Pralldüsen ca. 80l/min	Nozzles	Full-cone type apr. 50l/min; Impact type apr. 80l/min
Werkstoffe	Rohre und Zubehör Stahl feuerverzinkt, Halterungen Aluminium; Düsen Messing; Druckluftleitungen Kupfer; Erdleitungen duk. Gussrohr mit Verankerungsschellen (Beton Wiederlager bauseits); Druckwasserkessel innen 400 um Anstrich außen Grundanstrich gef. Isolierung.	Material	Water piping carbon steel hot galvanized; claps aluminium; nozzles brass; air piping copper; Underground piping cast steel with anchoring brackets (foundation not included); Pressure vessel inside coating 400 um outside primer 200 um optional isolated.

Für die Ausarbeitung eines Angebotes erbitten wir Zeichnungen des Transformators mit einem Lageplan der Anlage und Angaben über die Art der Wasserversorgung.

In order to submit a quotation we require drawings of the transformer, a site plan and information about the water supply system.

Sicherheitseinrichtung bei vorhandenem Druckluftnetz
Safety device if compr.-air net available

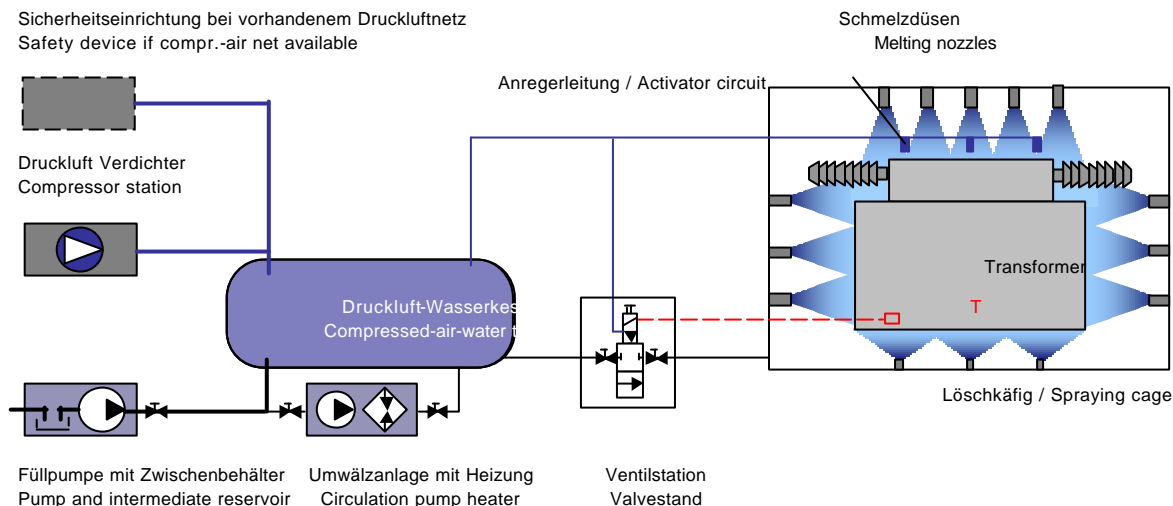

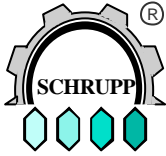

Druckwasser - Feuerlöschanlagen kühlen den Transformator und verhindern den Sauerstoffaustausch im Gefahrenfall bevor ein Brand entsteht und vermeiden im Gegensatz zu Schaumlöschanlagen die Zerstörung des teuren Equipments.

Water operated Fire Fighting Systems are cooling the transformator down and will stop the air circulation. The difference to an traditional foam fire fighting system is that the Schrupp system will prevent fire an helps to protect the expensive equipment.

Druckwasser - Feuerlöschanlagen für den Innenbereich verhindern Brände ohne dabei die im Raum befindlichen Personen, wie bei Gaslöschanlagen, zu gefährden.

Water operated Fire Fighting Systems prevent fire without any danger for the personal in the room, like gas operated fire fighting systems.



Die pneumatisch vorgesteuerte Ventile öffnen selbständig ohne Fremdenergie und schließen im Gegensatz zu Klappenventilen automatisch nach Beendigung des Löschvorganges, so das die noch im Druckbehälter vorhandene Luft nicht austreten kann. Mit Hilfe des vorgeschalteten Handschiebers können jederzeit Funktionsprüfung oder Wartungsarbeiten am Sytem durchgeführt werden ohne das Wasser versprüht oder der Druckbehälter entleert werden muß.

The pneumatically controlled valves are opening without any external energy and will close - in difference to standard flap valves - automatically after the fire fighting cycle to keep the compressed air in the pressure vessel. An additional manual gate valve allows system "dry" testing and maintenace without losing water.